

**GENERAL NOTES:**

- THE GENERAL CONTRACTOR IS RESPONSIBLE FOR THE PURCHASE AND INSTALLATION OF ALL FIRE EXTINGUISHERS REQUIRED BY LOCAL AND/OR NFPA CODES. THE CONTRACTOR SHALL MEET WITH THE LOCAL FIRE MARSHALL TO REVIEW AND CONFIRM FIRE EXTINGUISHER REQUIREMENTS PRIOR TO PURCHASING AND INSTALLING. FOR BIDDING PURPOSES, INCLUDE 15 EXTINGUISHERS IN BID.
- THE GENERAL CONTRACTOR SHALL PROVIDE 4" VINYL BASE AT ALL AREAS OF WALL NOT COVERED BY FIXTURES OR MILLWORK.
- THE GENERAL CONTRACTOR SHALL PROVIDE BLOCKING IN WALL AS NECESSARY WHERE OWNER SUPPLIED EQUIPMENT/ACCESSORIES ARE TO BE INSTALLED. VERIFY WITH HT PM.
- DIMENSIONS INDICATED ARE TO FACE OF CMU, CENTERLINE OF METAL STUDS, OR CENTERLINE OF DOOR UNLESS OTHERWISE NOTED. G.C. TO VERIFY EXISTING DIMENSIONS PRIOR TO CONSTRUCTION.

- KEY NOTES:**
- DECOR BOLLARD BY DECOR CONTRACTOR.
  - 12" WIDE PORTION OF END OF WALL TO EXTEND UP TO 6" ABOVE CEILING FOR ATTACHMENT TO DECK TO NEW ISLAND.
  - NEW HOME SHOPPING CALL BOX BY HT VENDOR AND INSTALLED BY G.C. COORDINATE EXACT LOCATION IN FIELD WITH HT PROJECT MANAGER.
  - MILLWORK WEDGE BY G.C. SEE DETAIL 18/ML.2.
  - CORNER CLOSURE PANEL. SEE DETAIL 17/ML.1.
  - G.C. TO PRESSURE WASH ENTIRE FRONT OF BUILDING AND ALL SIDEWALKS ACROSS FRONT OF BUILDING.
  - NEW DECORATIVE BOLLARDS BY G.C. SEE DETAIL 3/A1.2 AND FINISH SCHEDULE. COORDINATE EXACT LOCATIONS IN FIELD WITH LOCATION OF NEW HOME SHOPPING CALL BOX.
  - NOT USED.
  - G.C. TO REPAIR EXISTING AUTOMATIC ENTRY DOOR. VERIFY EXTENTS IN FIELD.
  - NOT USED.
  - G.C. TO HAVE ALL SURFACES IN PREP AREA PROFESSIONALLY CLEANED. VERIFY EXTENTS IN FIELD.
  - G.C. TO HAVE ALL SURFACES IN CAN WASH PROFESSIONALLY CLEANED. VERIFY EXTENTS IN FIELD.
  - G.C. TO HAVE ALL SURFACES IN RESTROOM PROFESSIONALLY CLEANED. VERIFY EXTENTS IN FIELD.
  - G.C. TO HAVE ALL SURFACES IN EMPLOYEE LOUNGE PROFESSIONALLY CLEANED. MAKE REPAIRS AS NECESSARY. VERIFY EXTENTS IN FIELD AND WITH HT PROJECT MANAGER.
  - G.C. TO HAVE EXISTING SUSPENDED CEILING TILES AND GRID PROFESSIONALLY CLEANED. REPLACE ANY DAMAGED OR STAINED TILES. VERIFY EXTENTS IN FIELD.
  - G.C. TO INSTALL NEW DOCK SEALS AND BUMPERS. SEE SPECIFICATIONS.
  - G.C. TO INSTALL NEW DOCK CANOPY. SEE SPECIFICATIONS. PAINT CANOPY TO MATCH EXISTING. VERIFY COLOR IN FIELD.
  - G.C. TO INSTALL NEW TRASH COMPACTOR CHUTE. NEW CHUTE TO MATCH EXISTING. VERIFY IN FIELD.
  - G.C. TO CLOSE OFF GAP AROUND BEAM WITH METAL STUDS AND GYPSUM BOARD. FINISH AND PAINT TO MATCH ADJACENT WALL. VERIFY COLOR AND EXTENTS IN FIELD.
  - NOT USED.
  - G.C. TO INSTALL NEW TRIM AROUND DAIRY COOLER DOORS. SEE DETAIL 12/A3.1. VERIFY EXTENTS IN FIELD.
  - NOT USED.
  - G.C. TO INSTALL NEW DECORATIVE BOLLARD COVERS ON EXISTING STEEL BOLLARDS. SEE DETAIL 3/A1.2. VERIFY EXTENTS IN FIELD.
  - G.C. TO CHECK COPING CAP, PARAPET WALL AND CANOPY ROOF FOR LOCATION OF WATER LEAK ABOVE EXISTING DOOR. REPAIR LEAK AS NECESSARY. COORDINATE FINDINGS AND REPAIRS WITH HT PROJECT MANAGER. VERIFY EXTENTS IN FIELD.
  - G.C. TO REPAIR EXISTING MILLWORK DOORS AND DRAWERS. VERIFY EXTENTS IN FIELD.
  - G.C. TO REPLACE (3) DOWNSPOUT GUARDS ON FRONT OF BUILDING. SEE DETAIL 4/A1.2. VERIFY EXTENTS IN FIELD.
  - NEW 15" TALL BY 9" TALL LETTERS, TYPICAL. COLOR OF ALL NEW STRIPPING AND LETTERS TO MATCH EXISTING. VERIFY IN FIELD.
  - NEW DIRECTIONAL ARROWS, TYPICAL. COLOR OF ALL NEW STRIPPING AND LETTERS TO MATCH EXISTING. VERIFY IN FIELD.
  - NEW STRIPPING, TYPICAL. STRIPPING TO BE ON A 45° ANGLE AND 12" APART. COLOR AND EXTENTS OF NEW STRIPPING TO MATCH EXISTING. VERIFY IN FIELD.
  - NEW 12" WIDE "STOP BAR" STRIPE. STRIPE TO BE ON A 45° ANGLE. COLOR OF NEW STRIPPING TO MATCH EXISTING. VERIFY IN FIELD.

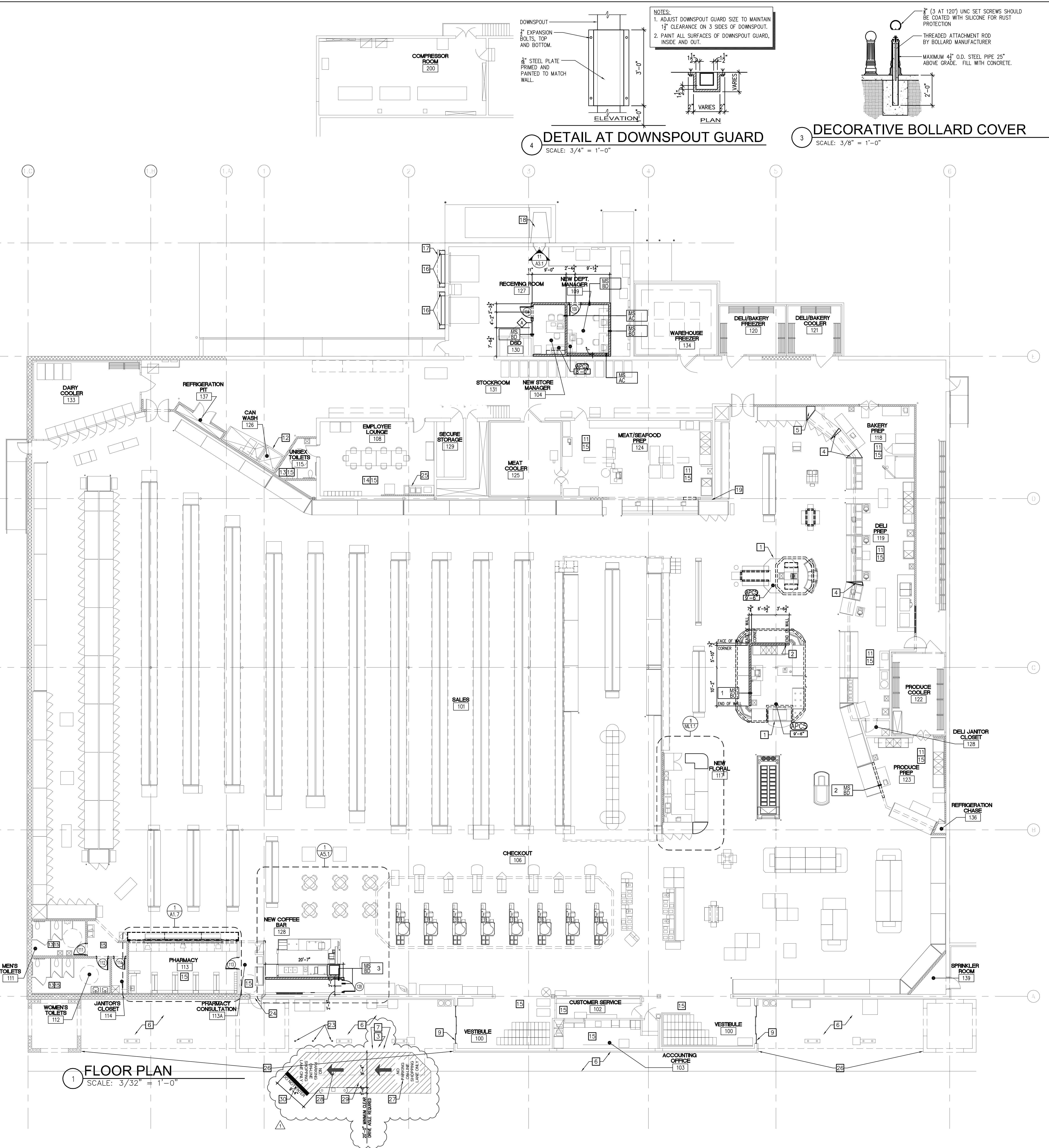
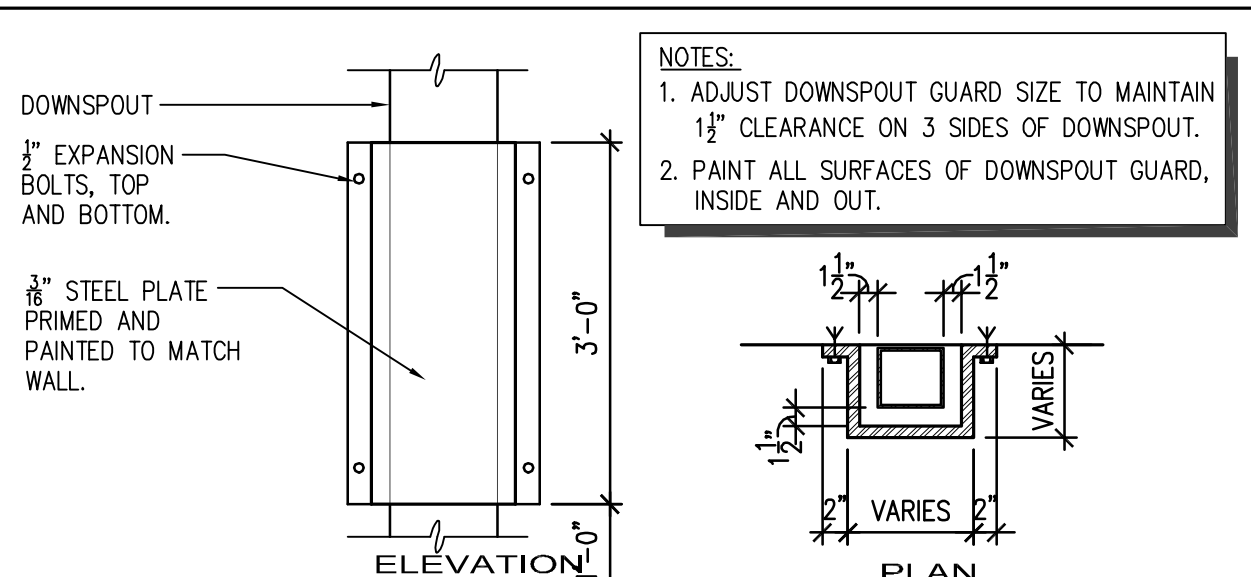
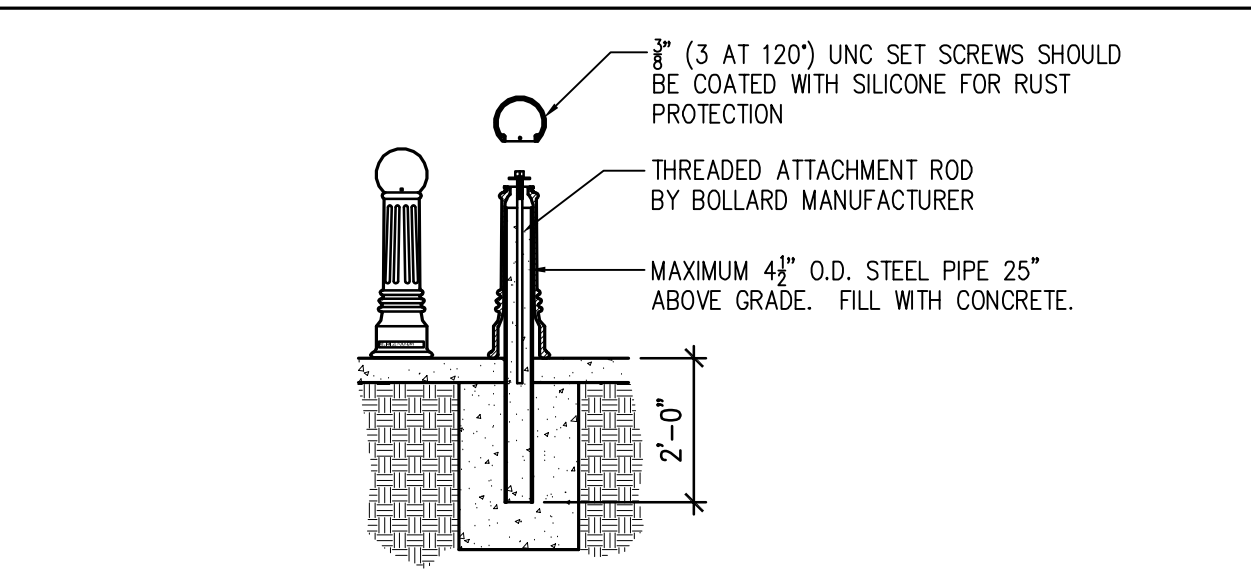
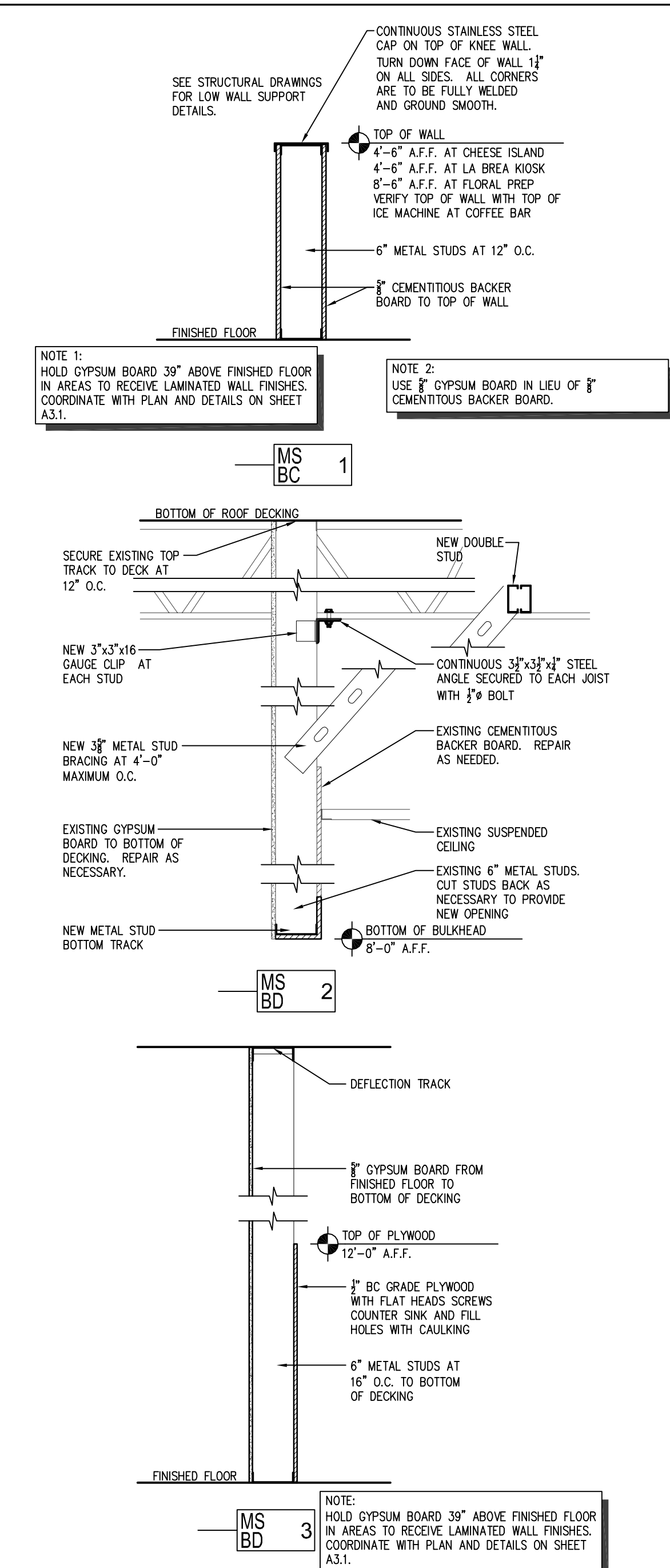

**CEILING TILE SCHEDULE**

APC2	2'x4' SUSPENDED ACOUSTICAL PANEL
APCS	2'x2' VINYL FACED TILES

**LEGEND**

⊠	2'x2' LIGHT FIXTURE
○	CAN LIGHT FIXTURE
⊞	DIFFUSER/RETURNS/EXHAUST
⊞	2'x2' PREFINISHED ACCESS PANEL